



DIAMOND-MM-AT



AT AUTOCALIBRATION TECHNOLOGY



DIAMOND-MM-AT offers autocalibration, programmable gain, A/D FIFO, and extended temperature operation to mid-range 12-bit analog I/O users. All these features are added on top of our existing Diamond-MM architecture at the same price as the original board, to bring you an unbeatable combination of features at this price level.

Analog Outputs

The board also has 2 12-bit analog outputs with multiple unipolar and bipolar output ranges. A new programmable output range feature lets you set the output range anywhere between 0V and 10V with 1mV precision in software.

Analog Inputs

The 16 12-bit analog input channels feature programmable gains of 1, 2, 4, and 8, as well as programmable unipolar/ bipolar range, for a total of 9 different input ranges. Maximum sampling rate is 100KHz (total for all channels), and a new 512-sample FIFO enables the board to operate at full speed in Windows operating systems using interrupts. DMA is no longer required to attain full speed.

ANALOG INPUT RANGES

Input Range	Resolution (1 LSB)
0 - 10V	2.44mV
0 - 5V	1.22mV
0 - 2.5V	0.061mV
0 - 1.25V	0.031mV
± 10V	4.88mV
± 5V	2.44mV
± 2.5V	1.22mV
± 1.25V	0.61mV
± 0.625V	0.31mV

Diamond-MM-AT offers 9 different programmable input ranges, including both unipolar and bipolar modes. Single-ended/differential operation is selected with jumpers, as it is with all our analog I/O boards.

FEATURES

- ◆ 16 analog inputs, 12-bit resolution
- ◆ 100KHz max sampling rate
- ◆ Programmable gain
- ◆ FIFO for gap-free sampling
- ◆ 2 12-bit analog outputs
- ◆ Programmable analog output range
- ◆ Autocalibration of both A/D and D/A
- ◆ 16 digital I/O lines
- ◆ +5V only power supply
- ◆ -40 to +85°C operation
- ◆ Drop-in upgrade for Diamond-MM

FREE SOFTWARE
See Page 49 for Details

DIAMOND-MM-AT BLOCK DIAGRAM

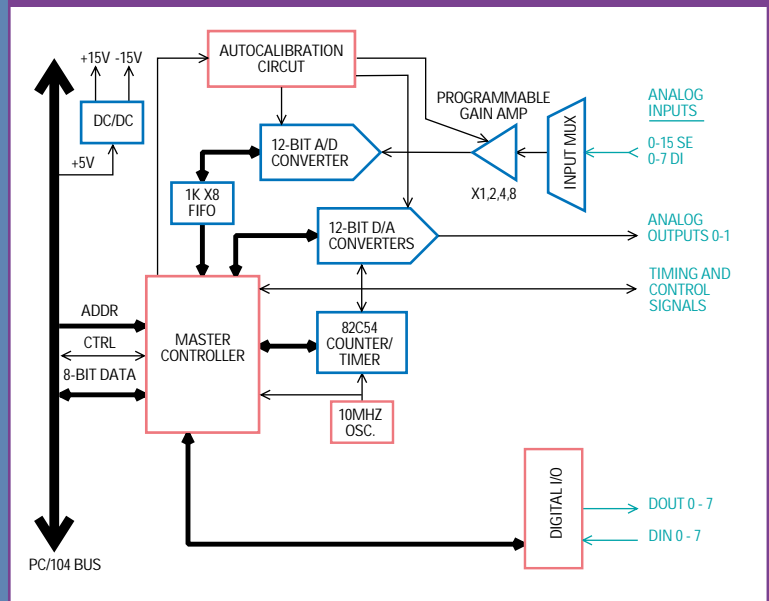

Autocalibration

Both analog inputs and outputs benefit from our unique multi-range autocalibration process. Multiple on-board precision references are used to calibrate the board in each range, thereby ensuring the highest degree of accuracy. The analog outputs are also fed back to the autocalibration circuit for precise output range calibration as well as user-programmable output ranges.

Counters and Digital I/O

The board also has an on-board counter/timer to control A/D sampling or rate generator functions, 8 digital inputs, and 8 digital outputs. New features enable you to generate hardware interrupts from the counter/timer as well as an external digital signal. And in keeping with our real-world-friendly design, Diamond-MM-AT requires only +5V power supply and operates over the full industrial temperature range of -40 to +85°C.

Compatible with Diamond-MM

The software architecture, connector pinout, and connector location of Diamond-MM-AT are identical to our existing Diamond-MM board, so users of that board can upgrade to take advantage of new features without any changes to their software or hardware. Even the price has been held constant, to make Diamond-MM-AT an unsurpassable value in its category of 12-bit analog I/O PC/104 boards.

I/O Header

Diamond-MM-AT's I/O header has the same pinout and the same location as the header on Diamond-MM.

I / O HEADER

VIN 15/7-	1	2	VIN 7/7+
VIN 14/6-	3	4	VIN 6/6+
VIN 13/5-	5	6	VIN 5/5+
VIN 12/4-	7	8	VIN 4/4+
VIN 11/3-	9	10	VIN 3/3+
VIN 10/2-	11	12	VIN 2/2+
VIN 9/1-	13	14	VIN 1/1+
VIN 8/0-	15	16	VIN 0/0+
ANALOG GND	17	18	VREF OUT
ANALOG GND	19	20	VOUT 0
ANALOG GND	21	22	VOUT 1
ANALOG GND	23	24	+15V
-15V	25	26	VREF IN 0
ANALOG GND	27	28	VREF IN 1
CTR IN 0-	29	30	DIGITAL GND
CTR OUT 0	31	32	CTR OUT 2
DOUT 7	33	34	DOUT 6
DOUT 5	35	36	DOUT 4
DOUT 3	37	38	DOUT 2
DOUT 1	39	40	DOUT 0
DIN 7	41	42	DIN 6
DIN 5	43	44	DIN 4
DIN 3	45	46	DIN 2/Gate 0
DIN 1	47	48	DIN 0/Gate 1/2
+5	49	50	DIGITAL GND

SPECIFICATIONS

Analog Inputs	
Number of inputs	8 differential or 16 single-ended (user selectable)
A/D resolution	12 bits (1/4096 of full scale)
Bipolar ranges	±10V, ±5V, ±2.5V, ±1.25V, ±0.625V,
Unipolar ranges	0-10V, 0-5V, 0-2.5V, 0-1.25V
Input bias current	3nA max
Max. input voltage	±10V for linear operation
Nonlinearity	±1LSB, no missing codes
Conversion rate	100,000 samples per second with interrupts
Conversion trigger	software trigger, internal pacer clock, or external TTL signal
Input FIFO	512 samples, interrupt on half-full
Analog Outputs	
Number of outputs	2
D/A resolution	12 bits (1/4096 of full scale)
Output ranges	Fixed: ±5V, 0-5V Programmable: anywhere between 0V and 10V in 1mV increments
Output current	± 5mA max per channel
Settling time	4µS max to ±1/2 LSB
Relative accuracy	± 1 LSB
Digital I/O	
Number of inputs	8, HCT/TTL compatible
Input voltage	Logic 0: 0.0V min, 0.8V max Logic 1: 2.0V min, 5.0V max
Input current	±1µA max
Number of outputs	8, HCT/TTL compatible
Output voltage	Logic 0: 0.0V min, 0.33V max Logic 1: 3.8V min, 5.0V max
Output current	Logic 0: 64mA max per line Logic 1: -15mA max per line
Counter/Timers	
A/D Pacer clock	32-bit down counter (2 82C54 counters cascaded)
Clock source	10MHz on-board source or external signal
General purpose	16-bit down counter (1 82C54 counter)
Interrupt trigger	End of A/D conversion or scan
General	
Calibration	A/D and D/A circuits calibrated under software control
Power supply	+5VDC ±10% @ 320mA typ
± 15V output current	± 10mA max with DACs unloaded
Operating temperature	-40 to + 85°C Extended
Weight	3.3 oz / 93g

Diamond Point International (Europe) Ltd

Suite 13, Ashford House, Beaufort Court

Sir Thomas Longley Road, Rochester, Kent, ME2 4FA, UK

Phone 01634 300900 - Fax 01634 722398 - Email sales@dpie.com - Web www.dpie.com



www.dpie.com